



5IF CFTU DIPJDF GPS DPOUJOVPVT EVUZ

% - # -

.BSJOF 5SBOTNJT

UISVTU CFB/SJOH ESJWF TIBGU

.JOJNJ[JOH UIF WBSJBUJPOT PO UIF QPXFS US

4USVDUVSF 'FBUVSFT

"EEJUJPOBM UISVTU CFBSJOHT BTTFNLEMCQBMRBZIF EESSWFDHFBBSB.SUDP MGE SFTUSBJOJOH TIBGU CFOEJOH BOE FOESVPSJSHU OIBSZTDBQP X FSGFWWFOSMOP BEYR

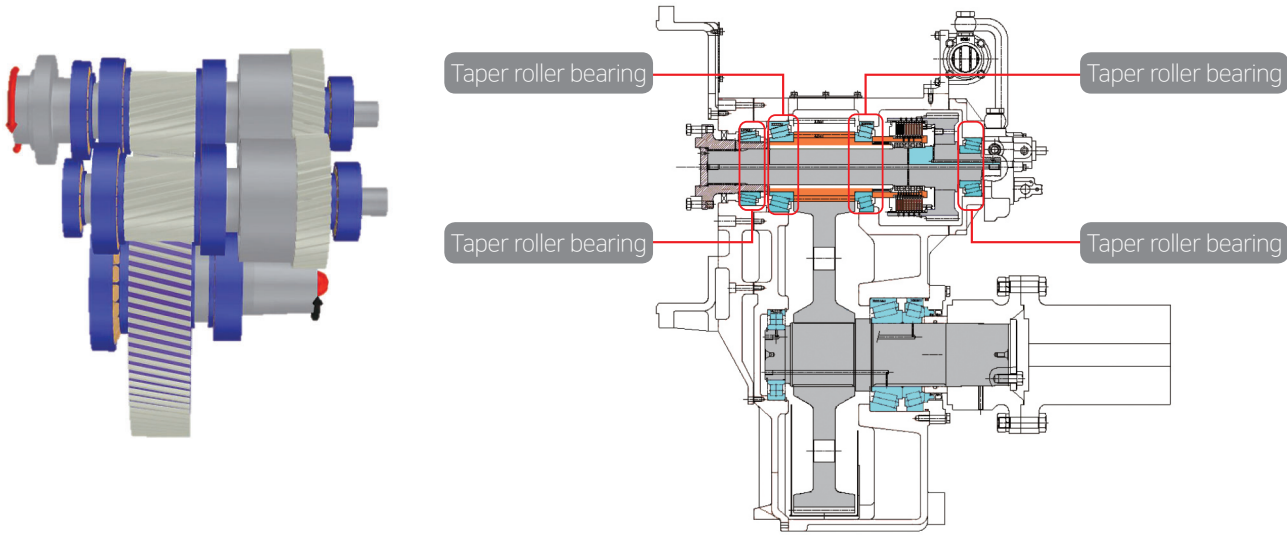

PEFM 'FBUVSFT

- %FTJHOFE JO BDDPSEBODF XJUI %/7 (- DFSUJGJDBUJ
- "QQMZJOH UIF DPSF UFDIOPMPHZ UPMFOSBUJOH TFWF
-)JHIMZ FMBTUJD DPVQMJOH PG \$FOUB BQQMJFE
- &BTZ NBJOUFOBODF TUSVDUVSF
- \$PNQBUDU MJHIU XFJHIU

.0% & -	3"5*0	. "9 */165	\$ "1"\$*5: 31.	31.	45"/%"3%
		50326& LHG N8)1	L8)064*/(4"&
% .5 % -					
% .5 % -					
% .5 % -					
% .5 # -					



MARINE TRANSMISSION
STEERING SYSTEM
POWER TAKE OFF

/BNHBOH SP CFPO HJM +JOKV TJ (ZFP OHTBOH OB
5 & - "9
&NBJM EJDME J DP LS 8FCTJUF XXX E J P L

[B2003A0201E]