

# MARINE TRANSMISSION

## DMT320H

### ■ Standard Scope Of Supply

- Bell Housing (SAE 0, 1)
- Centa Flexible Coupling (18", 14")
- Propeller Coupling, Reamer Bolt
- Manual Control Valve
- Oil Cooler
- Cable Bracket

### ■ Options

- Manual Trolling Valve
- Electronic Control Valve(12V,24V)
- Manual Trolling Valve + Electronic Control Valve(12V,24V)
- Mounting Bracket (Flat type, L type)

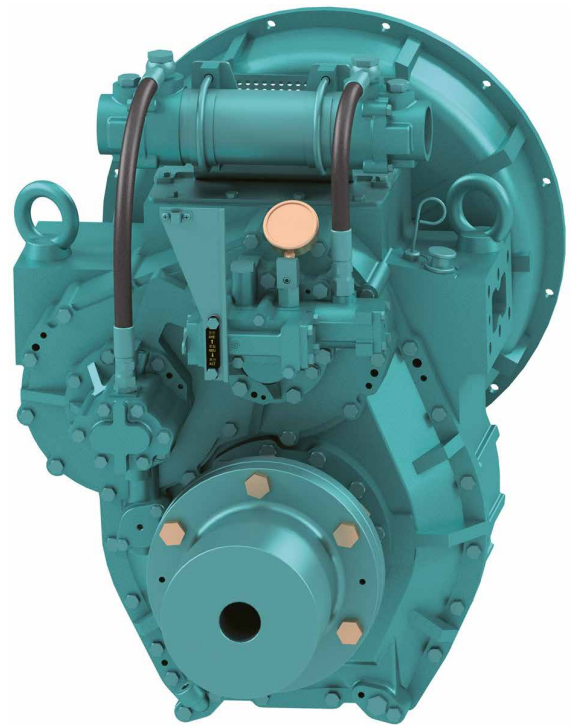

Model	Ratio	Max Input Torque		Capacity/RPM		Capacity/1800RPM		Max Input (RPM)	Bell Housing (SAE)	DRY WEIGHT (kg)
		(kgf.m)	(N.m)	kW	HP	kW	HP			
DMT320H	2.06, 2.50, 2.92	320	3139	0.328	0.440	591	793	2500	0, 1	400
	3.26	312	3060	0.320	0.429	576	773	2500		

※ The dry weight is the weight that excludes bell housing, coupling (rubber block, dual stage, Centa flexible) and propeller coupling from the standard scope of supply.

※ The capacity for classification may differ from the capacity on the table, please contact our sales team.

## DMT320H Dimensions

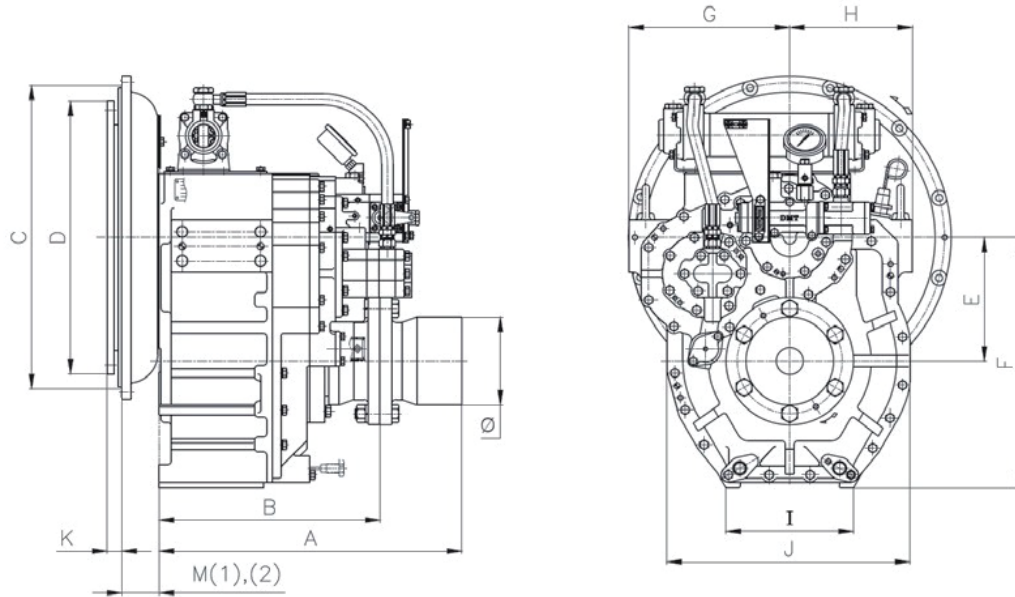

mm

A	B	E	F	G	H	I	J	Ø
653	453	254	484	330	235	276	458	190

mm

Bell Housing Standard	Driving Ring	C	D	M(1)	M(2)	K
SAE#0	18"	647	571	-	130	15
SAE#0	14"	647	466	-	130	25
SAE#1	14"	511	466	-	122	25

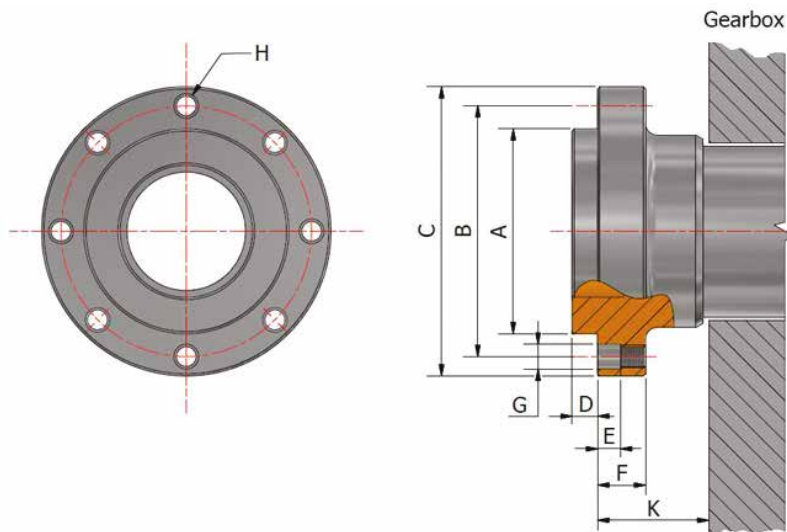

mm

A	B	C	D	E	F	G	H	K	
Ø129	$\begin{matrix} 0 \\ -0.02 \end{matrix}$	Ø155	Ø177	10.6	11	25	Ø12.55	8-M12 P1.25	35.7